

When are Timed Automata weakly timed bisimilar to Time Petri Nets ?

B. Bérard¹, F. Cassez², S. Haddad¹, D. Lime³, O.H. Roux²

¹ LAMSADE, Paris, France

E-mail: {beatrice.berard | serge.haddad}@lamsade.dauphine.fr

² IRCCyN, Nantes, France

{Franck.Cassez | Olivier-h.Roux}@irccyn.ec-nantes.fr

³ CISS, Aalborg, Denmark

Didier@cs.aau.dk

Abstract. In this paper, we compare Timed Automata (TA) with Time Petri Nets (TPN) with respect to weak timed bisimilarity. It is already known that the class of bounded TPNs is included in the class of TA. It is thus natural to try and identify the (strict) subclass \mathcal{TA}^{wtb} of TA that is equivalent to TPN for the weak time bisimulation relation. We give a characterisation of this subclass and we show that the membership problem and the reachability problem for \mathcal{TA}^{wtb} are *PSPACE*-complete. Furthermore we show that for a TA in \mathcal{TA}^{wtb} with integer constants, an equivalent TPN can be built with integer bounds but with a size exponential w.r.t. the original model. Surprisingly, using rational bounds yields a TPN whose size is linear.

Keywords: Time Petri Nets, Timed Automata, Weak Timed Bisimilarity.

1 Introduction

Expressiveness of timed models. The idea of adding explicit time to classical models was first introduced in the seventies for Petri nets [12,14]. Since then, timed models based on Petri nets and finite automata were extensively studied, and various tools were developed for their analysis. In this paper, we focus on two well known models: Timed Automata (TA) from [2] and Time Petri Nets (TPNs) from [12], where a closed time interval is associated with each transition. More precisely, we are interested in comparing the expressive power of the two models with respect to weak timed bisimulation. Recall that there are unbounded TPNs which do not admit a bisimilar TA. This is a direct consequence of the following observation: the untimed language of a TA is regular which is not necessarily the case for PNs (and thus for TPNs). On the other hand, it was proved in [8] that bounded TPNs form a subclass of the class of timed automata, in the sense that for each bounded TPN \mathcal{N} , there exists a TA which is weakly timed bisimilar to \mathcal{N} . A similar result can be found in [11], where it is obtained by a completely different approach. In another line of work [10], Haar, Kaiser, Simonot

& Toussaint compare Timed State Machines (TSM) and Time Petri Nets. They give a translation from TSM to TPN that preserves timed languages.

Our Contribution. In this work, we consider TPNs and label-free TA, *i.e.* where two different edges have different labels (and no label is ε) and we give a characterisation of the subclass \mathcal{TA}^{wtb} of timed automata which admit a weakly timed bisimilar TPN. This non intuitive condition relates to the topological properties of the so-called region automaton associated with a TA. To prove that the condition is necessary, we introduce the notion of *uniform bisimilarity*, which is stronger than weak timed bisimilarity. Conversely, when the condition holds for a TA, we provide two effective constructions of bisimilar TPNs: the first one with rational constants has a size linear w.r.t. the TA, while the other, which uses only integer constants has an exponential size. From this characterisation, we will deduce that given a TA, the problem of deciding whether there is a TPN bisimilar to it, is *PSPACE*-complete. Thus, we obtain that the membership problem is *PSPACE*-complete. Finally we also prove that the reachability problem is *PSPACE*-complete.

Outline of the paper. Section 2 recalls the semantics of TPNs and TA, and the notion of timed bisimilarity. Section 3 explains the characterisation while Section 4 is devoted to a sketch of its proof. Finally we propose some discussion in Section 5.

2 Time Petri Nets and Timed Automata

Notations. Let Σ be a finite alphabet, Σ^* (resp. Σ^ω) the set of finite (resp. infinite) words of Σ and $\Sigma^\infty = \Sigma^* \cup \Sigma^\omega$. We also use $\Sigma_\varepsilon = \Sigma \cup \{\varepsilon\}$ with ε (the empty word) not in Σ .

The sets \mathbb{N} , $\mathbb{Q}_{\geq 0}$ and $\mathbb{R}_{\geq 0}$ are respectively the sets of natural, non-negative rational and non-negative real numbers. We write $\mathbf{0}$ for the tuple $v \in \mathbb{N}^n$ such that $v(k) = 0$ for all $1 \leq k \leq n$. Let $g > 0$ in \mathbb{N} , we write $\mathbb{N}_g = \{\frac{i}{g} \mid i \in \mathbb{N}\}$. A tuple $v \in \mathbb{Q}^n$ belongs to the *g-grid* if $v(k) \in \mathbb{N}_g$ for all $1 \leq k \leq n$.

An interval I of $\mathbb{R}_{\geq 0}$ is a $\mathbb{Q}_{\geq 0}$ -interval iff its left endpoint belongs to $\mathbb{Q}_{\geq 0}$ and its right endpoint belongs to $\mathbb{Q}_{\geq 0} \cup \{\infty\}$. We set $I^\downarrow = \{x \mid x \leq y \text{ for some } y \in I\}$, the *downward closure* of I and $I^\uparrow = \{x \mid x \geq y \text{ for some } y \in I\}$, the *upward closure* of I . We denote by $\mathcal{I}(\mathbb{Q}_{\geq 0})$ the set of $\mathbb{Q}_{\geq 0}$ -intervals of $\mathbb{R}_{\geq 0}$.

Timed Transition Systems and Equivalence Relations. Timed transition systems describe systems which combine discrete and continuous evolutions. They are used to define and compare the semantics of TPNs and TA.

A *Timed Transition System (TTS)* is a transition system $S = (Q, q_0, \rightarrow)$, where Q is the set of configurations, $q_0 \in Q$ is the initial configuration and the relation \rightarrow consists of either delay moves $q \xrightarrow{d} q'$, with $d \in \mathbb{R}_{\geq 0}$, or discrete moves $q \xrightarrow{a} q'$, with $a \in \Sigma_\varepsilon$. Moreover, we require standard properties for the relation \rightarrow :

Time-Determinism: if $q \xrightarrow{d} q'$ and $q \xrightarrow{d} q''$ with $d \in \mathbb{R}_{\geq 0}$, then $q' = q''$,

0-delay: $q \xrightarrow{0} q$,

Additivity: if $q \xrightarrow{d} q'$ and $q' \xrightarrow{d'} q''$ with $d, d' \in \mathbb{R}_{\geq 0}$, then $q \xrightarrow{d+d'} q''$ and

Continuity: if $q \xrightarrow{d} q'$, then for every d' and d'' in $\mathbb{R}_{\geq 0}$ such that $d = d' + d''$, there exists q'' such that $q \xrightarrow{d'} q'' \xrightarrow{d''} q'$.

With these properties, a *run* of S can be defined as a finite or infinite sequence of moves $\rho = q_0 \xrightarrow{d_0} q'_0 \xrightarrow{a_0} q_1 \xrightarrow{d_1} q'_1 \xrightarrow{a_1} \dots q_n \xrightarrow{d_n} q'_n \dots$ where discrete actions alternate with durations. We also write this run as $q \xrightarrow{d_0 a_0 \dots d_n \dots} q'$. The word $Untimed(\rho)$ in Σ^∞ is obtained by the concatenation $a_0 a_1 \dots$ of labels in Σ_ε (so empty labels disappear), and $Duration(\rho) = \sum_{i=0}^{|\rho|} d_i$.

It is well-known that the notion of weak timed bisimilarity is central among equivalence relations between timed systems. From a TTS, we define the relation $\xrightarrow{a} \subseteq Q \times (\Sigma \cup \mathbb{R}_{\geq 0}) \times Q$ for $a \in \Sigma$ and $d \in \mathbb{R}_{\geq 0}$ by:

- $q \xrightarrow{d} q'$ iff $\exists \rho = q \xrightarrow{w} q'$ with $Untimed(\rho) = \varepsilon$ and $Duration(\rho) = d$,
- $q \xrightarrow{a} q'$ iff $\exists \rho = q \xrightarrow{w} q'$ with $Untimed(\rho) = a$ and $Duration(\rho) = 0$.

Definition 1 (Weak Timed Bisimilarity). Let $S_1 = (Q_1, q_0^1, \rightarrow_1)$ and $S_2 = (Q_2, q_0^2, \rightarrow_2)$ be two TTS and let \approx be a binary relation over $Q_1 \times Q_2$. We write $q \approx q'$ for $(q, q') \in \approx$. The relation \approx is a weak timed bisimulation between S_1 and S_2 iff $q_0^1 \approx q_0^2$ and for all $a \in \Sigma \cup \mathbb{R}_{\geq 0}$

- if $q_1 \xrightarrow{a} q'_1$ and $q_1 \approx q_2$ then $\exists q_2 \xrightarrow{a} q'_2$ such that $q'_1 \approx q'_2$;
- conversely, if $q_2 \xrightarrow{a} q'_2$ and $q_1 \approx q_2$ then $\exists q_1 \xrightarrow{a} q'_1$ such that $q'_1 \approx q'_2$.

Two TTS S_1 and S_2 are weakly timed bisimilar, written $S_1 \approx_{\mathcal{W}} S_2$, if there exists a weak timed bisimulation relation between them.

Strong timed bisimilarity would require similar properties for transitions labeled by $a \in \Sigma \cup \mathbb{R}_{\geq 0}$, but with \xrightarrow{a} instead of \xrightarrow{a} . Thus it does not take into account the possibility of splitting a run while keeping the global duration. In the rest of the paper, we abbreviate weak timed bisimilarity by bisimilarity and we explicitly name other equivalences when needed.

Time Petri Nets. Introduced in [12], and studied more recently in [13], Time Petri Nets (TPNs) associate a (closed) time interval with each transition.

Definition 2 (Labeled Time Petri Net). A Labeled Time Petri Net \mathcal{N} over Σ_ε is a tuple $(P, T, \Sigma_\varepsilon, \bullet(\cdot), (\cdot)^\bullet, M_0, \Lambda, I)$ where P is a finite set of places, T is a finite set of transitions with $P \cap T = \emptyset$, $\bullet(\cdot) \in (\mathbb{N}^P)^T$ is the backward incidence mapping, $(\cdot)^\bullet \in (\mathbb{N}^P)^T$ is the forward incidence mapping, $M_0 \in \mathbb{N}^P$ is the initial marking, $\Lambda : T \rightarrow \Sigma_\varepsilon$ is the labeling function and $I : T \mapsto \mathcal{I}(\mathbb{Q}_{\geq 0})$ associates with each transition a closed firing interval.

A TPN \mathcal{N} is a g -TPN if for all $t \in T$, the interval $I(t)$ has its bounds in \mathbb{N}_g . We also use $\bullet t$ (resp. t^\bullet) to denote the set of places $\bullet t = \{p \in P \mid \bullet t(p) > 0\}$ (resp. $t^\bullet = \{p \in P \mid t^\bullet(p) > 0\}$) as it is common in the literature.

A *marking* M of a TPN is a mapping in \mathbb{N}^P , with $M(p)$ the number of tokens in place p . A transition t is *enabled* in a marking M iff $M \geq \bullet t$. We denote by $En(M)$ the set of enabled transitions in M . An enabled transition t can be fired if the time elapsed since it was last enabled belongs to the interval $I(t)$, its firing resulting in the new marking $M' = M - \bullet t + t \bullet$. A *valuation* ν is a mapping in $(\mathbb{R}_{\geq 0})^{En(M)}$, where $\nu(t)$ represents the time elapsed since transition t was last enabled. It remains to define when a transition t is newly enabled, *i.e.* when the value $\nu(t)$ is reset. In this paper, we choose *persistent atomic semantics*, which is slightly different from the classical semantics [5,3], but equivalent when the net is bounded [4]. The predicate is defined by:

$$\uparrow enabled(t', M, t) = t' \in En(M - \bullet t + t \bullet) \wedge (t' \notin En(M)),$$

which amounts to consider that the firing of a transition is performed in an atomic step, the transition currently fired behaving like the other transitions.

The set $ADM(\mathcal{N})$ of (*admissible*) *configurations* consists of the pairs (M, ν) such that $\nu(t) \in I(t)^\downarrow$ for each transition $t \in En(M)$. Thus time can progress in a marking only up to the minimal endpoint of the intervals for all enabled transitions.

Definition 3 (Semantics of TPN). *The semantics of a TPN $\mathcal{N} = (P, T, \Sigma_\varepsilon, \bullet(\cdot), (\cdot)\bullet, M_0, \Lambda, I)$ is a TTS $S_{\mathcal{N}} = (Q, q_0, \rightarrow)$ where $Q = ADM(\mathcal{N})$, $q_0 = (M_0, \mathbf{0})$ and \rightarrow is defined by:*

- either a *delay move* $(M, \nu) \xrightarrow{d} (M, \nu + d)$ iff $\forall t \in En(M), \nu(t) + d \in I(t)^\downarrow$,
- or a *discrete move* $(M, \nu) \xrightarrow{\Lambda(t)} (M - \bullet t + t \bullet, \nu')$ where $\forall t' \in En(M - \bullet t + t \bullet)$, $\nu'(t') = 0$ if $\uparrow enabled(t', M, t)$ and $\nu'(t') = \nu(t)$ otherwise, iff $t \in En(M)$ is such that $\nu(t) \in I(t)$.

We simply write $(M, \nu) \xrightarrow{w}$ to emphasise that a sequence of transitions w can be fired. If $\text{Duration}(w) = 0$, we say that w is an *instantaneous firing sequence*. A net is said to be k -bounded if for each reachable configuration (M, ν) and for each place p , $M(p) \leq k$. **Timed Automata.** First defined in [2], the model of timed automata (TA) associates a set of non negative real-valued variables called *clocks* with a finite automaton.

Let X be a finite set of *clocks*. We write $\mathcal{C}(X)$ for the set of *constraints* over X , which consist of conjunctions of atomic formulas of the form $x \bowtie h$ for $x \in X$, $h \in \mathbb{Q}_{\geq 0}$ and $\bowtie \in \{<, \leq, \geq, >\}$.

Definition 4 (Timed Automaton). *A Timed Automaton \mathcal{A} over Σ_ε is a tuple $(L, \ell_0, X, \Sigma_\varepsilon, E, Inv)$ where L is a finite set of locations, $\ell_0 \in L$ is the initial location, X is a finite set of clocks, $E \subseteq L \times \mathcal{C}(X) \times \Sigma_\varepsilon \times 2^X \times L$ is a finite set of edges and $Inv \in \mathcal{C}(X)^L$ assigns an invariant to each location. An edge $e = \langle \ell, \gamma, a, R, \ell' \rangle \in E$ represents a transition from location ℓ to location ℓ' with guard γ and reset set $R \subseteq X$. We restrict the invariants to conjunctions of terms of the form $x \bowtie h$ for $x \in X$, $h \in \mathbb{N}$ and $\bowtie \in \{<, \leq\}$.*

When we need to consider label-free automata, we simply assume that each edge has a unique label, different from ε .

A valuation v is a mapping in $\mathbb{R}_{\geq 0}^X$. For a valuation v and $d \in \mathbb{R}_{\geq 0}$, the valuation $v + d$ is defined by $(v + d)(x) = v(x) + d$ for each clock x , and for $R \subseteq X$, the valuation $v[R \mapsto 0]$ maps each variable in R to the value 0 and agrees with v over $X \setminus R$. Constraints of $\mathcal{C}(X)$ are interpreted over valuations: we write $v \models \gamma$ when the constraint γ is satisfied by v .

Definition 5 (Semantics of TA). *The semantics of a TA $\mathcal{A} = (L, \ell_0, X, \Sigma_\varepsilon, E, Inv)$ is a TTS $S_{\mathcal{A}} = (Q, q_0, \rightarrow)$ where $Q = L \times (\mathbb{R}_{\leq 0})^X$, $q_0 = (\ell_0, \mathbf{0})$ and \rightarrow is defined by:*

- either a delay move $(\ell, v) \xrightarrow{d} (\ell, v + d)$ iff $v + d \models Inv(\ell)$,
- or a discrete move $(\ell, v) \xrightarrow{e} (\ell', v')$ iff there exists some $e = (\ell, \gamma, a, R, \ell') \in E$ s.t. $v \models \gamma$, $v' = v[R \mapsto 0]$ and $v' \models Inv(\ell')$.

Elementary zones of a TA. Recall [2] that, if m is the maximal constant appearing in atomic formulas $x \bowtie c$ of \mathcal{A} , an equivalence relation with finite index can be defined on clock valuations, leading to a partition of $(\mathbb{R}_{\geq 0})^X$, with the following property: two equivalent valuations have the same behaviour under progress of time and reset operations, with respect to the constraints. Note that a partition using any $K \geq m$ would have the same property. Also, the construction can be extended to a g -grid, by taking all constants of the form $\frac{i}{g}$, $0 \leq i \leq K \cdot g$ instead of $\{0, 1, \dots, m\}$. Finally, taking $K = +\infty$ (as depicted in Figure 1 on the left) leads to a similar structure except for the fact that the partition is infinite.

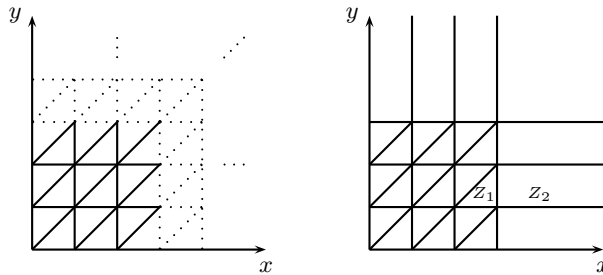

Fig. 1. Partitions of $(\mathbb{R}^+)^2$ with $K = +\infty$ and $K = 3$

In this paper, the elements of the partition are called *elementary zones* and we consider a slight variation for their definition: we take a constant $K \geq m + 1$ and with each clock $x \in X$, we associate an interval in the set $\{\{0\},]0, 1[, \{1\}, \dots, \{K-1\},]K-1, K[, [K, +\infty[$, instead of keeping $\{K\}$ separately. As usual, we also specify the ordering on the fractional parts for all clocks x such that $x < K$. Such a partition is represented in Figure 1 (on the right) for the set of two clocks $X = \{x, y\}$ and $K = 3$. For this example, elementary zones Z_1 and Z_2 are described by the constraints: $Z_1 : (2 < x < 3) \wedge (1 < y < 2) \wedge (0 < \text{frac}(y) < \text{frac}(x))$ and $Z_2 : (x \geq 3) \wedge (1 < y < 2)$.

If Z and Z' are elementary zones, Z' is a time successor of Z , written $Z \leq Z'$, if for each valuation $v \in Z$, there is some $d \in \mathbb{R}_{\geq 0}$ such that $v + d \in Z'$. For each elementary zone Z , there is at most one elementary zone such that (i) Z' is a time successor of Z , (ii) $Z \neq Z'$ and (iii) there is no time successor Z'' such that $Z \leq Z'' \leq Z'$. When it exists, this elementary zone is called the immediate successor of Z and is denoted by $\text{succ}(Z)$.

3 A characterisation of TA bisimilar to TPNs

Regions of a timed automaton. Since our results are mainly based on the *region automaton*, we recall its definition [2]. For a TA \mathcal{A} , the region automaton $R(\mathcal{A})$ is a finite automaton, with states of the form (ℓ, Z) , where ℓ is a location of \mathcal{A} and Z an elementary zone of $(\mathbb{R}_{\geq 0})^X$, for a constant K and a granularity g .

We call *region* a pair (ℓ, Z) as above. The regions of $R(\mathcal{A})$ are built inductively from the initial one $(\ell_0, \mathbf{0})$ by the following transitions over the set of labels $\{\text{succ}\} \cup \Sigma_\varepsilon$: $(\ell, Z) \xrightarrow{\text{succ}} (\ell, \text{succ}(Z))$ if $\text{succ}(Z) \models \text{Inv}(\ell)$ and $(\ell, Z) \xrightarrow{a} (\ell', Z')$ if there is a transition $(\ell, \gamma, a, R, \ell') \in E$ such that $Z \models \gamma$ and $Z' = Z[R \mapsto 0]$, with $Z' \models \text{Inv}(\ell')$. Thus, only *reachable* regions appear in $R(\mathcal{A})$. A region (ℓ, Z) is said to be *maximal* in $R(\mathcal{A})$ with respect to ℓ if no *succ*-transition is possible from (ℓ, Z) .

We now give a definition which distinguishes time-closed and time-open regions. It is equivalent to the original one but more convenient for our proofs and it fits both cases, whether K is finite or infinite.

Definition 6 (Regions of an automaton w.r.t. the g -grid and constant K). A *time-closed* (description of a) region r is given by:

- ℓ_r the location of r ,
 - $\min_r \in \mathbb{N}_g^X$ with $\forall x, \min_r(x) \leq K$, the minimal vector of the topological closure of r ,
 - $\text{Act}X_r = \{x \in X \mid \min_r(x) < K\}$ the subset of relevant clocks,
 - the number size_r of different fractional parts for the values of relevant clocks in the $\mathbb{N}_g^{\text{Act}X_r}$ grid, with $1 \leq \text{size}_r \leq \text{Max}(|\text{Act}X_r|, 1)$ and the onto mapping $\text{ord}_r : X \mapsto \{1, \dots, \text{size}_r\}$ giving the ordering of the fractional parts.
- By convention, $\forall x \in X \setminus \text{Act}X_r, \text{ord}_r(x) = 1$.

Then $r = \{(\ell_r, \min_r + \delta) \mid \delta \in \mathbb{R}_{\geq 0}^X \wedge \forall x, y \in \text{Act}X_r [\text{ord}_r(x) = 1 \Leftrightarrow \delta(x) = 0] \wedge \delta(x) < 1/g \wedge [\text{ord}_r(x) < \text{ord}_r(y) \Leftrightarrow \delta(x) < \delta(y)]\}$

A *time-open* (description of a) region r is defined with the same attributes (and conditions) as the time-closed region by:

$r = \{(\ell_r, \min_r + \delta + d) \mid d \in \mathbb{R}_{> 0} \wedge \forall x \in \text{Act}X_r, \delta(x) + d < 1/g\}$.

The set $[X]_r$ is the set of equivalence classes of clocks w.r.t. their fractional parts, i.e. x and y are equivalent iff $\text{ord}_r(x) = \text{ord}_r(y)$.

Remark that $\min_r \notin r$ except if there is a single class of clocks relative to r (for instance if the corresponding zone is a singleton). In the sequel, the topology of

the regions is implicitly derived from the one of its associated zone. We note \bar{r} , the topological closure of r : it is a finite union of regions and from the definition, \min_r is the minimum vector of \bar{r} .

Of course, when $K = +\infty$, the part about *relevant* clocks, for which the value is less than K , can be omitted (since $\text{Act}X_r = X$). While the case $K = +\infty$ results in an infinite partition, it makes some proofs simpler, because the extremal case where a clock value is greater than K is avoided. This hypothesis can be lifted afterward.

Furthermore when $K = +\infty$, a region admits a single description whereas when K is finite, some regions admit both time-open and time-closed descriptions (for instance a region associated with zone Z_2 in fig. 1). Note that time elapsing leads to an alternation of time-open regions (where time can elapse) and time-closed ones (where no time can elapse).

Reachability. For a reachable region r of $R(\mathcal{A})$, not all configurations of r are reachable. Nevertheless, by induction on the reachability relation inside $R(\mathcal{A})$, it can be shown that every configuration is *quasi-reachable* in the following sense: For any reachable region r , there is a region $\text{reach}(r)$ w.r.t. the 1-grid and constant $K = \infty$ such that (i) $\text{reach}(r) \subset r$, (ii) each configuration of $\text{reach}(r)$ is reachable and (iii) if $\text{reach}(r)$ is a time-open region then r admits a time-open description else r admits a time-closed description.

As a consequence, we have: $\forall x \in \text{Act}X_r, \min_{\text{reach}(r)}(x) = \min_r(x)$ and $\forall x \in X \setminus \text{Act}X_r, \min_{\text{reach}(r)}(x) \geq K$ and ord_r restricted to $\text{Act}X_r$ is identical to $\text{ord}_{\text{reach}(r)}$.

Consider the relation \mathcal{R} defined by $(l, v) \mathcal{R} (l, v')$ iff $\forall x \in X, v'(x) = v(x) \vee (v(x) \geq K \wedge v'(x) \geq K)$. Then \mathcal{R} is a strong timed bisimulation relation. From the previous observations, we note that each configuration of a reachable region is strongly time bisimilar to a reachable configuration of this region. Thus speaking about reachability of regions is a slight abuse of notations.

We can now state our main results.

Theorem 1 (Characterisation of TA bisimilar to some TPN). *Let \mathcal{A} be a (label-free) timed automaton and $R(\mathcal{A})$ its region automaton w.r.t. the 1-grid and a constant K strictly greater than any constant occurring in the automaton, then \mathcal{A} is weakly timed bisimilar to a time Petri net iff for each region r of $R(\mathcal{A})$ and for each edge e from \mathcal{A} ,*

- (a) *Every region r' such that $r' \cap \bar{r} \neq \emptyset$ is reachable*
- (b) *$\forall (l_r, v) \in r$, if $(l_r, v) \xrightarrow{e}$ then $(l_r, \min_r) \xrightarrow{e}$*
- (c) *$\forall (l_r, v) \in \bar{r}$, if $(l_r, \min_r) \xrightarrow{e}$ then $(l_r, v) \xrightarrow{e}$.*

Furthermore, if these conditions are satisfied then we can build a 1-bounded 2-TPN bisimilar to \mathcal{A} whose size is linear w.r.t. the size of \mathcal{A} and a 1-bounded 1-TPN bisimilar to \mathcal{A} whose size is exponential w.r.t. the size of \mathcal{A} .

We denote by $\mathcal{TA}^{\text{wtb}}$ the corresponding subclass of timed automata.

Theorem 2 (Complexity results). *Given a (label-free) timed automaton \mathcal{A} , deciding whether there is a TPN weakly timed bisimilar to \mathcal{A} is PSPACE-complete. The reachability problem for the class $\mathcal{TA}^{\text{wtb}}$ is PSPACE-complete.*

The characterisation of Theorem 1 is closely related to the topological closure of reachable regions: it states that any region intersecting the topological closure of a reachable region is also reachable and that a discrete step either from a region or from the minimal vector of its topological closure is possible in the whole topological closure. Consider the two TA \mathcal{A}_0 and \mathcal{A}_1 in Figure 2. The automaton \mathcal{A}_0 admits a bisimilar TPN whereas \mathcal{A}_1 does not. Indeed, the region $r = \{(\ell_1, x = 1 \wedge 0 < y < 1)\}$ is reachable. The guard of edge c is true in $\min_r = (\ell_1, (1, 0))$ whereas it is false in r .

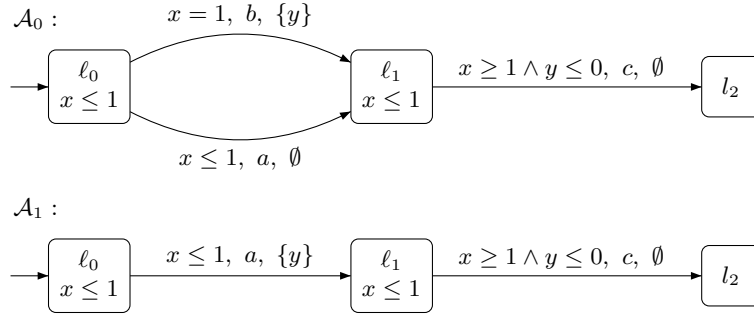

Fig. 2. Two automata with different behaviour w.r.t bisimulation with a TPN

The next section is devoted to a sketch of the proof of Theorem 1. Some additional formal proofs are given in the Appendix. The complete proofs can be found in [4].

4 Proof of Theorem 1

4.1 Necessary condition

From bisimulation to uniform bisimulation. As a first step, we prove that when a TPN and a TA are bisimilar, this relation can in fact be strengthened in what we call *uniform bisimulation*. We first need a lemma which points out the effect of time granularity on the behaviour of TPN. The proof is in the Appendix.

Lemma 1. *Let (M, ν) and $(M, \nu + \delta)$ be two admissible configurations of a g -TPN with $\nu, \delta \in \mathbb{R}_{\geq 0}^{En(M)}$. Let w be an instantaneous firing sequence, then:*

- (i) $(M, \nu) \xrightarrow{w}$ implies $(M, \nu + \delta) \xrightarrow{w}$
- (ii) If $\nu \in \mathbb{N}_g^{En(M)}$ and $\delta \in [0, 1/g]^{En(M)}$ then $(M, \nu + \delta) \xrightarrow{w}$ implies $(M, \nu) \xrightarrow{w}$

Lemma 2 is the central point for the proof of necessity. It shows that bisimulation implies uniform bisimulation for the g -grid with $K = \infty$. Uniform bisimulation means that given a reachable region, one can exhibit first a configuration of the net bisimilar to the minimal point of the region and secondly a mapping

from the enabled transitions of this configuration to the clocks of the automaton such that for any configuration inside the topological closure of this region one obtains a bisimilar configuration of the net using this mapping. Roughly speaking, a unique mechanism is used for every configuration of the topological closure of the region to obtain a bisimilar configuration of the net.

Lemma 2 (From bisimulation to uniform bisimulation). *Let \mathcal{A} be a timed automaton bisimilar to some g -TPN \mathcal{N} via some relation \mathcal{R} and let $R(\mathcal{A})$ be the region automaton of \mathcal{A} w.r.t. the g -grid and the constant $K = \infty$. Then:*

- if a region r belongs to $R(\mathcal{A})$ then \bar{r} also belongs to $R(\mathcal{A})$;
- for each reachable region r , there exist a configuration of the net (M_r, ν_r) with $\nu_r \in \mathbb{N}_g^{En(M_r)}$ and a mapping $\phi_r : En(M_r) \rightarrow [X]_r$ such that:
 - If r is time-closed, then for each $\delta \in \mathbb{R}_{\geq 0}^X$ such that $(\ell_r, \min_r + \delta) \in \bar{r}$, $(\ell_r, \min_r + \delta) \mathcal{R} (M_r, \nu_r + \text{proj}_r(\delta))$,
 - If r is time-open, then for each $\delta \in \mathbb{R}_{\geq 0}^X$, $d \in \mathbb{R}_{\geq 0}$ such that $(\ell_r, \min_r + \delta + d) \in \bar{r}$, $(\ell_r, \min_r + \delta + d) \mathcal{R} (M_r, \nu_r + \text{proj}_r(\delta) + d)$,
 where $\text{proj}_r(\delta)(t) = \delta(\phi_r(t))$.

Proof. First note that the choice of a particular clock x in the class $\phi_r(t)$ is irrelevant when considering the value $\delta(x)$. Thus the definition of proj_r is sound. The proof is an induction on the transition relation in the region automaton. The basis case is straightforward with $\{(l_0, \mathbf{0})\}$ and $\{(M_0, \mathbf{0})\}$. The induction part relies on lemma 1, with 4 cases, according to the incoming or target region and to the nature of the step: 1. a time step from a time-closed region, 2. a time step from a time-open region, 3. a discrete step into a time-closed region, and 4. a discrete step into a time-open region.

Detailed proofs for these cases are given in the Appendix. \square

Proof of Necessity. The fact that conditions (a), (b) and (c) of Theorem 1 are satisfied with respect to the g -grid and constant $K = \infty$ is straightforward:

(a) This assertion is included in the inductive assertions.

(b) Let r be a reachable region, let $(\ell_r, \min_r + \delta) \in r$ be a configuration with $\delta \in [0, 1/g]^X$, then $\exists(M, \nu)$ $\nu \in \mathbb{N}_g^{En(M)}$ bisimilar to (ℓ_r, \min_r) and $(M, \nu + \delta')$ with $\delta' \in [0, 1/g]^{En(M)}$ bisimilar to $(\ell_r, \nu + \delta)$. Suppose that $(\ell_r, \min_r + \delta) \xrightarrow{e}$, then $(M, \nu + \delta') \xrightarrow{w}$ with w an instantaneous firing sequence and $\text{label}(w) = e$. Now by lemma 1-b, $(M, \nu) \xrightarrow{w}$, thus $(\ell_r, \min_r) \xrightarrow{e}$.

(c) Let r be a region, and $(\ell_r, \min_r + \delta) \in \bar{r}$ with $\delta \in [0, 1/g]^X$ thus $\exists(M, \nu)$ bisimilar to (ℓ_r, \min_r) and $(M, \nu + \delta')$ with $\delta' \in [0, 1/g]^{En(M)}$ bisimilar to $(\ell_r, \min_r + \delta)$. Suppose that $(\ell_r, \min_r) \xrightarrow{e}$, then $(M, \nu) \xrightarrow{w}$ with w an instantaneous firing sequence and $\text{label}(w) = e$. Now by lemma 1-a, $(M, \nu + \delta') \xrightarrow{w}$, thus $(\ell_r, \min_r + \delta) \xrightarrow{e}$.

In order to complete the proof, we successively show that if the conditions are satisfied by the g -grid and $K = \infty$, they also hold for the 1-grid and $K = \infty$, and finally that they are satisfied by the 1-grid and the usual finite constant. This is done by Lemmas 3 and 4, stated and proved in the Appendix.

4.2 Sufficient condition

Starting from a TA \mathcal{A} satisfying the conditions of Theorem 1, we build a 2-TPN bisimilar to \mathcal{A} . We describe the construction and give the proof of correctness in the Appendix. We do not present here the construction of a 1-TPN, which can be found in [4].

For this construction, all edges are weighted by 1. Omitted labels for transitions stand for ε . A firing interval $[0, 0]$ is indicated by a blackened transition and intervals $[0, \infty[$ are omitted. A double arrow between a place p and a transition t indicates that p is both an input and an output place for t .

W.l.o.g. we assume that an invariant never forbids to enter a state (by adding constraints to the input transitions). We then remark that $x < c$ occurring in an invariant of \mathcal{A} may be safely omitted. If it would forbid the progress of time in some configuration, then the associated region would be a maximal time-open region r . Due to condition (a), \bar{r} is reachable but since r is time-open, $\bar{r} \cap \text{succ}(r) \neq \emptyset$, so that $\text{succ}(r)$ is reachable which contradicts the maximality of r .

Clock constraints. The atomic constraints associated with a clock x are arbitrarily numbered from 1 to $n(x)$ where $n(x)$ is the number of such conditions. When $x \leq h$ occurs in at least one transition and in at least one invariant, we consider it as two different conditions. Then we add places $(Rtodo_i^x)_{i \leq n(x)+1}$ for the reset operations.

We build a subnet for each atomic constraint $x \bowtie h$ occurring in a transition of the TA, and one for each condition $x \leq h$ occurring in an invariant. Figure 3 below shows the subnets corresponding to $x < h$ (with $h > 0$) on the left and $x \leq h$ on the right. Since constant $\frac{1}{2}$ appears in interval bounds, the resulting TPN is a 2-TPN.

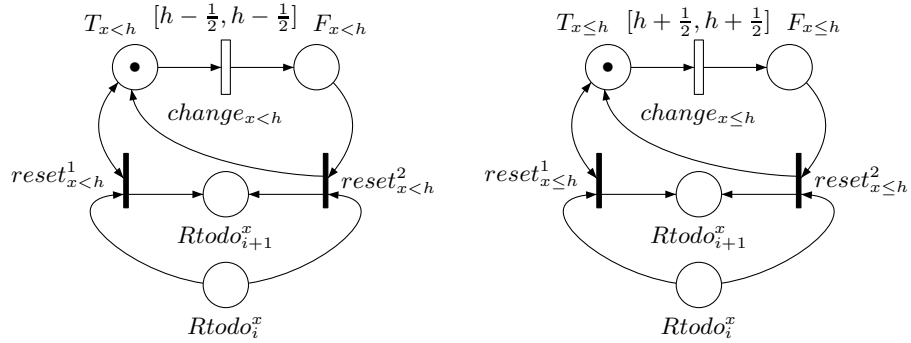

Fig. 3. The subnets for $x < h$ (with $h > 0$) and $x \leq h$

Locations and edges. With each location ℓ of the automaton, we associate an eponymous place ℓ . The place ℓ is initially marked iff the location ℓ is the initial one. The invariant $Inv(\ell)$ is tested with the subnets corresponding to its

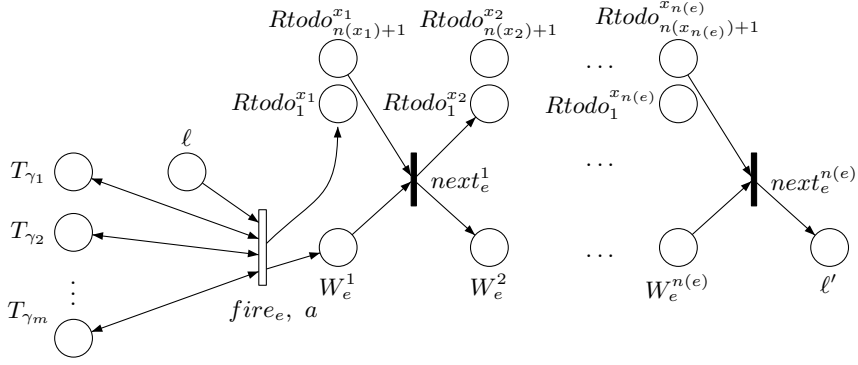

Fig. 4. The subnet for edge $e = (\ell, \gamma = \gamma_1 \wedge \dots \wedge \gamma_{m(e)}, a, R = \{x_1, \dots, x_{n(e)}\}, \ell')$

atomic constraints. To simulate an edge $(\ell, \gamma, a, R, \ell')$, we must test the atomic constraints from $\gamma = \gamma_1 \wedge \dots \wedge \gamma_{m(e)}$, using the places corresponding to true in the associated subnets, and reset successively all the clocks in $R = \{x_1, \dots, x_{n(e)}\}$ by instantaneous transitions. This is done by the subnet in Figure 4.

5 Conclusion

In this paper, we considered the (semantic) subclass \mathcal{TA}^{wtb} of labeled-free TA such that a timed automaton \mathcal{A} is in \mathcal{TA}^{wtb} if and only if there is a TPN \mathcal{N} weakly timed bisimilar to \mathcal{A} . We obtained a characterisation of this class, based on the region automaton associated with \mathcal{A} . To prove that our condition is necessary, we introduced the notion of uniform bisimulation between TA and TPNs. For the sufficiency, we proposed two constructions. From this characterisation, we have proved that for the class \mathcal{TA}^{wtb} , the membership problem and the reachability problem are *PSPACE*-complete. The techniques introduced here also lead to a similar characterisation for TA with diagonal constraints and to a simpler one for TA without strict or diagonal constraints (see [4]), the complexity results being unchanged. These techniques also give some insight for use of the region automaton in order to obtain expressivity results.

References

1. L. Aceto and F. Laroussinie. Is Your Model Checker on Time? On the Complexity of Model Checking for Timed Modal Logics. *Journal of Logic and Algebraic Programming*, volume 52-53, pages 7-51. Elsevier Science Publishers, august 2002.
2. R. Alur and D. Dill. A theory of timed automata. *Theoretical Computer Science B*, 126:183–235, 1994.
3. T. Aura and J. Lilius. A causal semantics for time Petri nets. *Theoretical Computer Science*, 243(1–2):409–447, 2000.
4. B. Bérard, F. Cassez, S. Haddad, D. Lime and O.H. Roux. Comparison of the Expressiveness of Timed Automata and Time Petri Nets. Research Report IRCCyN R2005-2 available at <http://www.lamsade.dauphine.fr/~haddad/publis.html> 2005.

5. B. Berthomieu and M. Diaz. Modeling and verification of time dependent systems using time Petri nets. *IEEE Transactions on Software Engineering*, 17(3):259–273, March 1991.
6. B. Berthomieu and M. Menasche. An enumerative approach for analyzing time Petri nets. In *Information Processing*, volume 9 of *IFIP congress series*, pages 41–46. Elsevier Science Publishers, 1983.
7. B. Berthomieu and F. Vernadat. State class constructions for branching analysis of time Petri nets. In *TACAS'2003*, volume 2619 of *LNCS*, pages 442–457, 2003.
8. F. Cassez and O. H. Roux. Structural Translation of Time Petri Nets into Timed Automata. In Michael Huth, editor, *Workshop on Automated Verification of Critical Systems (AVoCS'04)*, Electronic Notes in Computer Science. Elsevier, August 2004.
9. D. L. Dill. Timing assumptions and verification of finite-state concurrent systems. In Proc. Workshop on Automatic Verification Methods for Finite State Systems, Grenoble, volume 407 of *LNCS*, 1989.
10. S. Haar, F. Simonot-Lion, L. Kaiser, and J. Toussaint. Equivalence of Timed State Machines and safe Time Petri Nets. In *Proceedings of WODES 2002*, Zaragoza, Spain, pages 119–126.
11. D. Lime and O. H. Roux. State class timed automaton of a time Petri net. In *PNPM'03*. IEEE Computer Society, September 2003.
12. P. M. Merlin. *A study of the recoverability of computing systems*. PhD thesis, University of California, Irvine, CA, 1974.
13. M. Pezzé and M. Young. Time Petri Nets: A Primer Introduction. Tutorial presented at the Multi-Workshop on Formal Methods in Performance Evaluation and Applications, Zaragoza, Spain, september 1999.
14. C. Ramchandani. *Analysis of asynchronous concurrent systems by timed Petri nets*. PhD thesis, Massachusetts Institute of Technology, Cambridge, MA, 1974.

A Necessity

A.1 Proof of Lemma 1

Proof. There are two kinds of transitions firing in w : those corresponding to a firing of a transition (say t) still enabled from the beginning of the firing sequence and those corresponding to a newly enabled transition (say t').

Proof of (a) Since t is firable from (M, ν) , $\nu(t) \in I(t) \subset I(t)^\uparrow$, so $\nu(t) + \delta(t) \geq \nu(t)$ also belongs to $I(t)^\uparrow$. Since $t \in En(M)$ and $(M, \nu + \delta)$ is reachable, $\nu(t) + \delta(t) \in I(t)^\downarrow$. Thus $\nu(t) + \delta(t) \in I(t)$ and t is also firable from $(M, \nu + \delta)$. Since t' is newly enabled, $0 \in I(t')$ and t' is also firable when it occurs starting from $(M, \nu + \delta)$.

Proof of (b) The case of newly enabled transitions in w is handled as before. Now let t be firable in $(M, \nu + \delta)$. Since $t \in En(M)$ and (M, ν) is reachable, $\nu(t) \in I(t)^\downarrow$. Since $\nu(t) + \delta(t) \in I(t)^\uparrow$, (denoting by $eft(t)$ the minimum of $I(t)^\uparrow$), we have $eft(t) \leq \nu(t) + \delta(t)$ but $eft(t)$ belongs to the g -grid, thus $eft(t) \leq \nu(t) \Leftrightarrow \nu(t) \in I(t)^\uparrow$. So t is firable from (M, ν) . \square

A.2 Proof of Lemma 2

Proof (of points 1, 2, 3, 4). **1. A time step from a time-closed region.** Let r be a time-closed region which is not maximal and let us denote $r' = \text{succ}(r)$ the immediate time successor of r . Let $(\ell_r, \min_r + \delta_0)$ be some item of r . $(\ell_r, \min_r + \delta_0) \xrightarrow{d}$ for some $d > 0$. Thus (by induction hypothesis) in \mathcal{N} there is a step sequence of $(M_r, \nu_r + \text{proj}_r(\delta_0)) \xrightarrow{d_0 t_1 \dots t_n d_n}$ with all transitions labelled by ϵ and $\sum d_k = d$. Let d_k be the first non zero elapsing of time. By application of lemma 1-b, the firing sequence $t_1 \dots t_k$ is fireable from (M_r, ν_r) .

Let us choose $(M_{r'}, \nu_{r'})$ the configuration reached by this sequence. By application of lemma 1-a, this firing sequence is also fireable from any $(M_r, \nu_r + \text{proj}_r(\delta))$ bisimilar to $(\ell_r, \min_r + \delta) \in \bar{r}$ and it leads to $(M_{r'}, \nu_{r'} + \text{proj}_{r'}(\delta))$ (still bisimilar to $(\ell_r, \min_r + \delta)$) where $\phi_{r'}$ (resp. $\nu_{r'}$) is equal to ϕ_r (resp. ν_r) for transitions always enabled during the firing sequence and $\phi_{r'}$ (resp. $\nu_{r'}$) is obtained by associating the class of index 1 (resp. by associating the value 0) to the transitions newly enabled. Since $(M_{r'}, \nu_{r'})$ let the time elapse and since \mathcal{N} is a g -TPN, we note that $\forall t \in \text{En}(M_{r'}), \nu_{r'}(t) + 1/g \in I(t)^\perp$. Now let $(\ell_r, \min_r + \delta + d) \in \bar{r}'$, one has $\forall x \in X, \delta(x) + d \leq 1/g$. Thus $\forall t \in \text{En}(M_{r'}), \text{proj}_{r'}(\delta(x)) + d \leq 1/g$, which implies $(M_{r'}, \nu_{r'} + \text{proj}_{r'}(\delta)) \xrightarrow{d} (M_{r'}, \nu_{r'} + \text{proj}_{r'}(\delta) + d)$, this last configuration being necessarily bisimilar to $(\ell_r, \min_r + \delta + d)$.

2. A time step from a time-open region. Let r be an time-open region and let us denote $r' = \text{succ}(r)$. Let us define X_r^{max} the class $[x]_r$ with maximal index. We remark that $\min_{r'} = \min_r + \delta_0$ where if $x \in X_r^{\text{max}}$ then $\delta_0(x) = 1/g$ else $\delta_0(x) = 0$. We choose $(M_{r'}, \nu_{r'}) = (M_r, \nu_r + \text{proj}_r(\delta_0))$. Let $t \in \text{En}(M_r)$ and $x \in \phi_r(t)$ then $\phi_{r'}(t) = [x]_{r'}$ (letting time elapse does not split the classes). So proj_r and $\text{proj}_{r'}$ are identical.

Now let $(\ell_{r'}, \min_{r'} + \delta) \in \bar{r}'$. $(\ell_{r'}, \min_{r'} + \delta) = (\ell_r, \min_r + \delta_0 + \delta)$.

Now let $d = \delta(x)$ for x belonging the class of index 1 in $[X_r]$. Then $(\ell_r, \min_r + \delta_0 + \delta) = (\ell_r, \min_r + \delta' + d)$ where if $x \in X_r^{\text{max}}$ then $\delta'(x) = 1/g - d$ else $\delta'(x) = \delta(x) - d$. $(\ell_r, \min_r + \delta' + d)$ is bisimilar to $(M_r, \nu_r + \text{proj}_r(\delta') + d) = (M_r, \nu_r + \text{proj}_r(\delta' + d)) = (M_r, \nu_r + \text{proj}_r(\delta_1 + \delta)) = (M_r, \nu_r + \text{proj}_r(\delta_1) + \text{proj}_r(\delta)) = (M_{r'}, \nu_{r'} + \text{proj}_{r'}(\delta))$.

For this step, we have not used the characteristics of time Petri nets.

3. A discrete step into a time-closed region.

Case a. We first consider the case where r is a time-closed region.

Let $(\ell_r, \min_r + \delta_0)$ be some element of r . Suppose that $(\ell_r, \min_r + \delta_0) \xrightarrow{\epsilon} (\ell', \nu' + \delta'_0)$ with $\forall x \in R(e), \nu'(x) = \delta'_0(x) = 0, \forall x \notin R(e), \nu'(x) = \min_r(x) \wedge \delta'_0(x) = \delta_0(x)$. Then in \mathcal{N} there is a firing sequence $(M_r, \nu_r + \text{proj}_r(\delta_0)) \xrightarrow{w}$ labeled by e . Due to lemma 1, this firing sequence is also fireable from any $(M_r, \nu_r + \text{proj}_r(\delta))$ bisimilar to $(\ell_r, \min_r + \delta) \in \bar{r}$. By bisimilarity, $(\ell_r, \min_r + \delta) \xrightarrow{\epsilon}$ for any $(\ell_r, \min_r + \delta) \in \bar{r}$. Let r' be the region including $(\ell', \nu' + \delta'_0)$, then any configuration of \bar{r}' is reachable by this discrete step. Note that $\ell_{r'} = \ell'$ and $\min_{r'} = \nu'$.

From $(M_r, \nu_r + proj_r(\delta))$, the sequence w leads to some (M', ν') bisimilar to $(\ell_{r'}, min_{r'} + \delta')$. We now show how to define $M_{r'}$, $\nu_{r'}$ and $\phi_{r'}$. First $M_{r'} = M'$. Second, $\nu_{r'}(t) = \nu_r(t)$ for transitions t always enabled during the firing sequence and $\nu_{r'} = 0$ otherwise. At last, $\phi_{r'}$ is obtained from ϕ_r as follows. Let t be a transition newly enabled during the firing sequence, then $\phi_{r'}(t)$ is associated to the class of index 1. Let t be a transition always enabled during the firing sequence. There are three cases to consider for $\phi_{r'}(t)$: either there is a $x \in \phi_r(t)$ not reset, then $\phi_{r'}(t) = |x|_{r'}$ otherwise $\phi_{r'}(t)$ is the class of maximal index which precedes $\phi_r(t)$ and contains a clock not reset or else the class of index 1. The two last affectations are sound since it means that whatever the value of $\delta(t)$ fulfilling the order between classes, the firing sequence w leads to bisimilar configurations (as being bisimilar to the same configuration of the automaton).

Case b. The case where r is a time-open region is handled in a similar way.

Let $(\ell_r, min_r + \delta_0 + d_0)$ be some element of r . Suppose that $(\ell_r, min_r + \delta_0 + d_0) \xrightarrow{e} (\ell', v' + \delta'_0)$ with $\forall x \in R(e), v'(x) = \delta'_0(x) = 0, \forall x \notin R(e), v'(x) = min_r(x) \wedge \delta'_0(x) = \delta_0(x) + d_0$. Then in \mathcal{N} there is a firing sequence $(M_r, \nu_r + proj_r(\delta_0) + d_0) \xrightarrow{w}$ labeled by e . Due to lemma 1, this firing sequence is also fireable from any $(M_r, \nu_r + proj_r(\delta) + d)$ bisimilar to $(\ell_r, min_r + \delta + d) \in \bar{r}$. By bisimilarity, $(\ell_r, min_r + \delta + d) \xrightarrow{e}$ for any $(\ell_r, min_r + \delta + d) \in \bar{r}$. Let r' be the region including $(\ell', v' + \delta'_0)$, then any configuration of \bar{r}' is reachable by this discrete step. Note that $\ell_{r'} = \ell'$ and $min_{r'} = v'$.

From $(M_r, \nu_r + proj_r(\delta) + d)$, the sequence w leads to some (M', ν') bisimilar to $(\ell_{r'}, min_{r'} + \delta')$. We now show how to define $M_{r'}$, $\nu_{r'}$ and $\phi_{r'}$. First $M_{r'} = M'$. Second, $\nu_{r'}(t) = \nu_r(t)$ for transitions t always enabled during the firing sequence and $\nu_{r'} = 0$ otherwise. At last, $\phi_{r'}$ is obtained from ϕ_r as follows. Let t be a transition newly enabled during the firing sequence, then $\phi_{r'}(t)$ is associated to the class of index 1. There are three cases to consider for $\phi_{r'}(t)$: either there is a $x \in \phi_r(t)$ not reset, then $\phi_{r'}(t) = |x|_{r'}$ otherwise $\phi_{r'}(t)$ is the class of maximal index which precedes $\phi_r(t)$ and contains a clock not reset or else the class of index 1. The two last affectations are sound since it means that whatever the value of $\delta(t)$ fulfilling the order between classes, the firing sequence w leads to bisimilar configurations (as being bisimilar to the same configuration of the automaton).

4. A discrete step into a time-open region. In order to reach a time-open region by a discrete step, the corresponding transition must start from a time-open region and must not reset any clock. Let $(\ell_r, min_r + \delta + d) \in r$ and $(\ell_r, min_r + \delta + d) \xrightarrow{e} (\ell', min_r + \delta + d)$. Here we have used the hypothesis that no clock is reset. Then there is a firing sequence $(M_r, \nu_r + proj_r(\delta) + d) \xrightarrow{w}$ labeled by e . Due to the lemma 1, $(M_r, \nu_r + proj_r(\delta)) \xrightarrow{w}$. $(\ell_r, \nu_r + \delta)$ is bisimilar to $(M_r, \nu_r + proj_r(\delta))$. Thus $(\ell_r, min_r + \delta) \xrightarrow{e} (\ell', min_r + \delta) \xrightarrow{d} (\ell', min_r + \delta + d)$. Then this region can be reached via a discrete step into a time-closed region followed by a time step. So we do not need to examine this case. \square

A.3 Lemmas 3 and 4

We may safely assume that any atomic constraint related to a clock x occurring in the invariant of a location is added to the guard of each incoming transition which does not reset x .

Lemma 3 (about the conditions and the grid). *Let \mathcal{A} be a timed automaton, $K = \infty$ and $g > 0$ in \mathbb{N} . If conditions (a),(b),(c) are satisfied by the region automaton associated with the g -grid, then they are satisfied by the region automaton associated with the 1-grid.*

Proof (of lemma 3). Let us denote by $R(\mathcal{A})^g$ the region automaton of A w.r.t. the g -grid. By definition of regions, we remark that r a region of $R(\mathcal{A})$ is a finite union of regions of $R(\mathcal{A})^g$ (say $r = \bigcup_{i=1..k} r_i$). Thus $\bar{r} = \bigcup_{i=1..k} \bar{r}_i$ which proves the implication for (a).

Assume that (b) is satisfied by $R(\mathcal{A})^g$. Let $(\ell_r, \min_r + \delta + d) \in r$ be a region of $R(\mathcal{A})$ and assume $(\ell_r, \min_r + \delta + d) \xrightarrow{e}$. We define δ' by $\delta'(x) = \delta(x)/g$. Then since \mathcal{A} has integer constraints $(\ell_r, \min_r + \delta' + d/g) \xrightarrow{e}$. Moreover this configuration belongs to r and then to a region $r' \in R(\mathcal{A})^g$ whose minimal vector is $\min_{r'}$. Then applying (b), we obtain $(\ell_r, \min_r) \xrightarrow{e}$.

Assume that (c) is satisfied by $R(\mathcal{A})^g$. Let $(\ell_r, v) \in \bar{r}$ where r is a region of $R(\mathcal{A})$ and assume $(\ell_r, \min_r) \xrightarrow{e}$. Then there is an increasing path among the minimum vectors of regions of $R(\mathcal{A})^g$ all included in \bar{r} . This path is such that any two consecutive elements belong to the closure of some region; it starts at (ℓ_r, \min_r) and finishes at (ℓ_r, \min_{r_*}) such that $(\ell_r, v) \in \bar{r}_*$ (with r_* a region of $R(\mathcal{A})^g$). Thus applying iteratively (c) yields $(\ell_r, v) \xrightarrow{e}$. \square

Lemma 4 (about the conditions and the constant K). *Let \mathcal{A} be a timed automaton. If conditions (a),(b),(c) are satisfied by the region automaton associated with the 1-grid and $K = \infty$, then they are satisfied by the region automaton associated with the 1-grid and a finite constant.*

Proof (of lemma 4). Let us denote $R(\mathcal{A})^\infty$ the region automaton of A w.r.t. $K = \infty$. Let r be a reachable region in $R(\mathcal{A})$ and $reach(r)$ the associated region of $R(\mathcal{A})^\infty$. Note that $\ell_{reach(r)} = \ell_r$ and that $\forall x \in ActX_r, \min_{reach(r)} = \min_r$ and $\forall x \in X, \min_{reach(r)} \geq \min_r$. Suppose that $reach(r)$ is time-closed (resp. time-open) then r admits a time-closed (resp. time-open) description where the ord_r and $ord_{reach(r)}$ mappings are identical for clocks in $ActX_r$. Thus $\forall (\ell_r, v) \in r, \exists (\ell_r, v') \in reach(r)$ such that $\forall x \in ActX_r, v'(x) = v(x)$.

Now take a convergent sequence $\lim_{i \rightarrow \infty} (\ell_r, v_i) = (\ell_r, v)$ with $(\ell_r, v_i) \in r$ so that $(\ell_r, v) \in \bar{r}$. Then the corresponding sequence $\{(\ell_r, v'_i)\}$ being bounded admits an accumulation point $(\ell_r, v') \in \bar{r}$. It is routine to show that (ℓ_r, v) and (ℓ_r, v') belong to the same region in $R(\mathcal{A})$. This proves that condition (a) for $R(\mathcal{A})^\infty$ implies condition (a) for $R(\mathcal{A})$.

Assume that (b) is satisfied by $R(\mathcal{A})^\infty$. Let $(\ell_r, v) \in r$ be a reachable region of $R(\mathcal{A})$ and $(\ell_r, v) \xrightarrow{e}$. Let $reach(r)$ be the associated reachable region of $R(\mathcal{A})^\infty$

then $\exists(\ell_r, v') \in reach(r)$ strongly time bisimilar to (ℓ_r, v) , thus $(\ell_r, v') \xrightarrow{e}$. Using condition (b), $(\ell_r, min_{reach(r)}) \xrightarrow{e}$. Since $(\ell_r, min_{reach(r)})$ is strongly time bisimilar to (ℓ_r, min_r) , we have $(\ell_r, min_r) \xrightarrow{e}$.

Assume that (c) is satisfied by $R(\mathcal{A})^\infty$ and consider $(\ell_r, v) \in \bar{r}$ where r is a region of $R(\mathcal{A})$ and $(\ell_r, min_r) \xrightarrow{e}$. Let $reach(r)$ be the associated reachable region of $R(\mathcal{A})^\infty$, then $\exists(\ell_r, v') \in reach(r)$ strongly time bisimilar to (ℓ_r, v) . Since $(\ell_r, min_{reach(r)})$ is strongly time bisimilar to (ℓ_r, min_r) , $(\ell_r, min_{reach(r)}) \xrightarrow{e}$. Thus using condition (c), $(\ell_r, v') \xrightarrow{e}$. By bisimilarity, we obtain $(\ell_r, v) \xrightarrow{e}$. \square

B Proof of the first construction of Theorem 1

We decompose the reachable configurations (and markings) into *intermediate* ones (some W_e^i is marked) and *permanent* ones (some ℓ is marked). An easy induction shows that in permanent configurations (M, ν) the enabled timed transitions relative to a clock are “synchronised”: $\nu(change_c) = \nu(change_{c'}) = \nu(reach_{c'})$ as soon as c, c', c'' relates to the same clock x . We define $\nu(x)$ as this common value if at least one such transition is enabled and otherwise $\nu(x) = K(x)$ where $K(x)$ is the maximal value relative to clock x occurring in the net \mathcal{N} . Furthermore from any intermediate configuration (M, ν) , the behaviour of the net is quasi-deterministic until it reaches a permanent configuration: there are only firing sequences (i.e. no time step) and some of them lead to permanent configurations. Furthermore these permanent configurations (say (M_{next}, ν_{next})) have the same marked place ℓ and the same values $\nu_{next}(x)$.

It is also obvious that once some $fire_e$ is fired, the construction ensures the existence of a “resetting” sequence which re-initialises the widgets associated to the clocks to be reset.

Bisimulation relation. We now define the relation \mathcal{R} between reachable configurations of the automaton \mathcal{A} and the net \mathcal{N} . Let us define $(\ell, v)\mathcal{R}(M, \nu)$ iff:

- either M is a permanent marking and $M(\ell)$ is marked and if $\nu(x) < K(x)$ then $v(x) = \nu(x)$ else $v(x) \geq K(x)$.
- or M is an intermediate marking leading to some permanent (M_{next}, ν_{next}) and $(\ell, v)\mathcal{R}(M_{next}, \nu_{next})$. This definition is sound due to the common features of the different (M_{next}, ν_{next}) .

It remains to prove that \mathcal{R} is a bisimulation, which is done in the next lemma.

Lemma 5. *The relation \mathcal{R} defined above is a weak timed bisimulation.*

Proof. We first consider moves from \mathcal{A} .

Case 1: $(\ell, v) \xrightarrow{e} (\ell', v')$ First, let us prove that $(M, \nu) \xrightarrow{\sigma}$ with σ labeled by e . At first, σ begins by σ' which consists to fire all the $change_c$ fireable leading to some (M', ν') (with $(\ell, v)\mathcal{R}(M', \nu')$). Now we prove that $(M', \nu') \xrightarrow{fire_e}$. By definition of \mathcal{R} , $M(\ell)$ is marked. Let c be a condition occurring in the guard of

e.

If $c = [x \geq a]$ then $v(x) \geq a$ which implies

$\nu(x) \geq a$ and that $T_{x \geq a}$ is marked (eventually with the help of σ').

If $c = [x > a]$ then let r be the region to which (ℓ, v) belongs. $\min_r(x) = \lfloor v(x) \rfloor$.

Using condition (b), $(\ell, \min_r) \xrightarrow{e}$. Thus $v(x) \geq \min_r(x) \geq a + 1$ which implies $\nu(x) \geq a + 1$ and that $T_{x > a}$ is marked (eventually with the help of σ').

If $c = [x \leq a]$ then $v(x) \leq a$ which implies $\nu(x) \leq a$ and that $T_{x \leq a}$ is marked (remember that $\text{change}_{x \leq a}$ fires when $\nu(x) = a + 1/2$).

If $c = [x < a]$ then let r be the region to which (ℓ, v) belongs. Then there exists $(\ell, v_1) \in \bar{r}$ with $v_1(x) = \lceil v(x) \rceil$. Using condition (b) and then (c), $(\ell, v_1) \xrightarrow{e}$.

Thus $v(x) \leq v_1(x) \leq a - 1$ which implies $\nu(x) \leq a - 1$ and that $T_{x < a}$ is marked (remember that $\text{change}_{x < a}$ fires when $\nu(x) = a - 1/2$).

Thus fire_e is fireable from (M', ν') . We complete σ by the “resetting” sequence leading to a configuration bisimilar to (ℓ', v')

If M is an intermediate marking, one fires a sequence leading to some $(M_{\text{next}}, \nu_{\text{next}})$ and performs the previous simulation.

Case 2: $(\ell, v) \xrightarrow{d} (\ell, v + d)$

Suppose that $x \leq a$ belongs to the invariant of ℓ . This means that $v(x) + d \leq a$. Thus from (M, ν) , we let a time d elapse interleaved with possible firings of change transitions. The stop transitions associated to ℓ will be possibly fireable but only at the end of this step sequence.

If M is an intermediate marking, one fires a sequence leading to some $(M_{\text{next}}, \nu_{\text{next}})$ and performs the previous simulation.

Conversely, we consider moves from \mathcal{N} .

Case 3: $(M, \nu) \xrightarrow{t} (M', \nu')$

If t is labeled by ϵ , then by construction $(\ell, v)\mathcal{R}(M', \nu')$.

Thus we only to need to examine the case of fire_e (M is then a permanent marking). Let r be the region to which (ℓ, v) belongs. We will show that $(\ell, \min_r) \xrightarrow{e}$. Then by condition (c), we will obtain that $(\ell, v) \xrightarrow{e}$.

Let c be a condition occurring in the guard of e .

If $c = [x \geq a]$ then $T_{x \geq a}$ is marked which implies that $\nu(x) \geq a$ and then $v(x) \geq a$, thus $\min_r(x) = \lfloor v(x) \rfloor \geq a$.

If $c = [x > a]$ then $T_{x > a}$ is marked which implies that $\nu(x) \geq a + 1$ and then $v(x) \geq a + 1$ thus $\min_r(x) = \lfloor v(x) \rfloor \geq a + 1 > a$

If $c = [x \leq a]$ then $T_{x \leq a}$ is marked which implies that $\nu(x) \leq a + 1/2$ and then $v(x) \leq a + 1/2$ thus $\min_r(x) = \lfloor v(x) \rfloor \leq a$

If $c = [x < a]$ then $T_{x < a}$ is marked which implies that $\nu(x) \leq a - 1/2$ and then $v(x) \leq a - 1/2$ thus $\min_r(x) = \lfloor v(x) \rfloor \leq a - 1 < a$

So $(\ell, v) \xrightarrow{e} (\ell', v')$ for some (ℓ', v') . By construction of \mathcal{N} and definition of \mathcal{R} , $(\ell', v')\mathcal{R}(M', \nu')$.

Case 4: $(M, \nu) \xrightarrow{d} (M, \nu + d)$

An intermediate marking cannot let elapse time. Thus M is a permanent marking. Let $x \leq a$ belonging to the invariant of

l . $a \neq 0$ otherwise from (M, ν) , $stop_l$ must be fired and time may not elapse. Similarly since $stop_l^{x \leq a}$ is only possibly fireable from $(M, \nu + d)$, it follows that $\nu(x) + d \leq a$, thus $v(x) + d \leq a$.

Consequently $(\ell, v) \xrightarrow{d} (\ell, v + d)$ and obviously $(\ell, v + d) \mathcal{R}(M, \nu + d)$. \square

C Proof of Theorem 2

The reachability problem for regions of a TA is in *PSPACE* [2].

In order to check whether the condition (a) is false we *non deterministically* pick a region r and a region r' which intersects \bar{r} and check whether r is reachable and r' is not reachable.

In order to check whether the condition (b) is false we *non deterministically* pick a region r and an edge e and check whether r is reachable and e is fireable from r and not fireable from (l_r, min_r) .

In order to check whether the condition (c) is false we *non deterministically* pick a region r , a region r' which intersects \bar{r} and an edge e and check whether r is reachable and e is not fireable from r or r' and fireable from (l_r, min_r) .

By Savitch construction, we obtain a deterministic algorithm in *PSPACE*.

In order to show the *PSPACE*-hardness, we use the construction given in [1] (in appendix D) which reduces the acceptance problem for linear bounded Turing machine (LBTM) to the reachability problem for TA with restricted guards. The computed TA (called $A_{\mathcal{M}, w_0}$) satisfies the conditions (a) and (b) but does not satisfy the condition (c). However it can be safely transformed in order to satisfy this condition by adding the invariant $t \leq 1$ to any state (q, i) and the invariant $t \leq 0$ to any state (i, θ, j) . This intermediate automaton is now bisimilar to a TPN.

Then we transform the edges entering the *end* state by resetting t and at last we add an edge $(end, t = 0, e, \emptyset, end)$.

If the LBTM \mathcal{M} does not accept the word w_0 , then the state *end* is not reachable and $A_{\mathcal{M}, w_0}$ satisfies the conditions (a), (b), (c).

If the LBTM \mathcal{M} accepts the word w_0 , then the state *end* is reachable and $A_{\mathcal{M}, w_0}$ does not satisfy the condition (c) (the additional edge is fireable when entering *end* but not after letting the time elapse). The fact that the reachability problem for the class \mathcal{TA}^- is *PSPACE*-complete was proved implicitly within the proof above.